



Triton - Model 0

INSTRUCTION MANUAL



CONTENTS

Introduction	3
Where to find the Serial No & Size Labels	3
Measurements & Useful Info	4
Seating System Components	5
Important Safety Advice	6
Important Safety Advice -(Accessories)	7
Important - Chest Harness Adjustment	8
Important - Lap Strap Safety	9
Lever Use - Using Index Plungers	10
Operation of Locking Levers	10
Adjusting Seat Depth	11
Mounting of Seating Unit	12
Removal of Seating Unit From Base	13
Operating Brakes	13
Adjusting The 5 Star Base	14
Adjusting The Multi Height & Tilt Base	15
Back Angle Adjustment	16
Back Height Adjustment	16
Adjusting Shoulder Protraction Pads	17
Fitting a Tray	18
Arm Rest and Tray Angle Adjustment	18
Hip Pad Adjustment	19
Lateral Support Adjustment	19
Headrest Adjustment	20
Sacral Pad Adjustment	21
Footplate & Leg Rest Adjustment	22
Footrest, Footplate & Sandal Adjustment	23
Cleaning & Care	24
General Maintenance	24
Servicing via Approved Repairer	25
Service Record Log	26
Warranty	27
Inspecting & Reissuing of Equipment	28

Introduction

The Triton 0 is designed to provide comfort and postural support for very young children.

This instruction manual contains very important information about the Triton 0 seating system, how to use it safely and obtain the best results from it. Please read all the information contained in this manual before using the chair and retain for future reference. Ensure everyone using the equipment is aware of the contents of this manual and understands how to use the equipment safely.

These instructions provide guidance on the adjustments for professionals, but they also give information on how the equipment should be safely used, maintained, checked, and correctly assembled by anyone who uses the seating system.

In every case the equipment should be supplied via qualified professionals who will have adjusted the equipment, checked its compliance and tested it appropriately.

The seating system should only ever be adjusted by qualified professionals and persons that are suitably trained. For further information please do not hesitate to contact us - all contact details are on the back cover of the manual.

Thank you for purchasing our product, we hope you enjoy your new seating system.

Where to find the Serial No & Size Labels

Serial Number

Located at the lower back of the seat on the inside of the back angle adjustment section.



Handle Size

Located on the right hand side of the handle where the handle feeds beneath the seating unit.



Seating Unit Size

Located on the right hand side underneath the seating unit, just above where the leg rest joins.



The model name can be found either side of the seat here.

Measurements & Useful Info

MEASUREMENTS (inches)	TRITON 0	
	MIN	MAX
A Seat Depth	6	11¼
B Seat to Top of Back	9¾	13¾
C Chest Breadth	5	8¾
D Seat to Footplate	5	8¼
E Seat Width (Between Hip Pads)	6	10¾
F Floor to Seat	4 Inch Castors: Min 14 Max 32 / 3 Inch Castors: Min 12¾ Max 30	
G Tilt in Space / Prone	Prone 17° Tilt 25°	
H Back Angle	25° Recline 5° Forward	
I Base Footprint	29 x 22½	
J User Weight	Maximum 220.4 lbs	

Triton 0	
Chair Weight	8.8 lbs

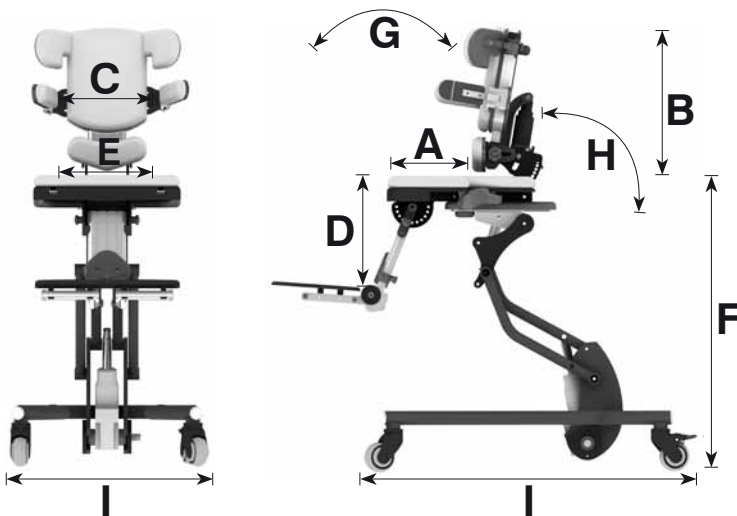

Please Note

All measurements given for indication only. JCM can tailor the chair to your exact requirements. Our representatives will assess your child to ensure the chair is fit for purpose both now and for the future.

Seating System Components

- A Push Handle
- B Headrest
- C Shoulder Protraction Pads
- D Lateral Supports
- E Hip Pads
- F Long Sitting Pad
- G Footplate
- H Castors
- I Multi Height & Tilt Base
- J Clear Tray
- K Armrest

Other accessories are available (not shown)

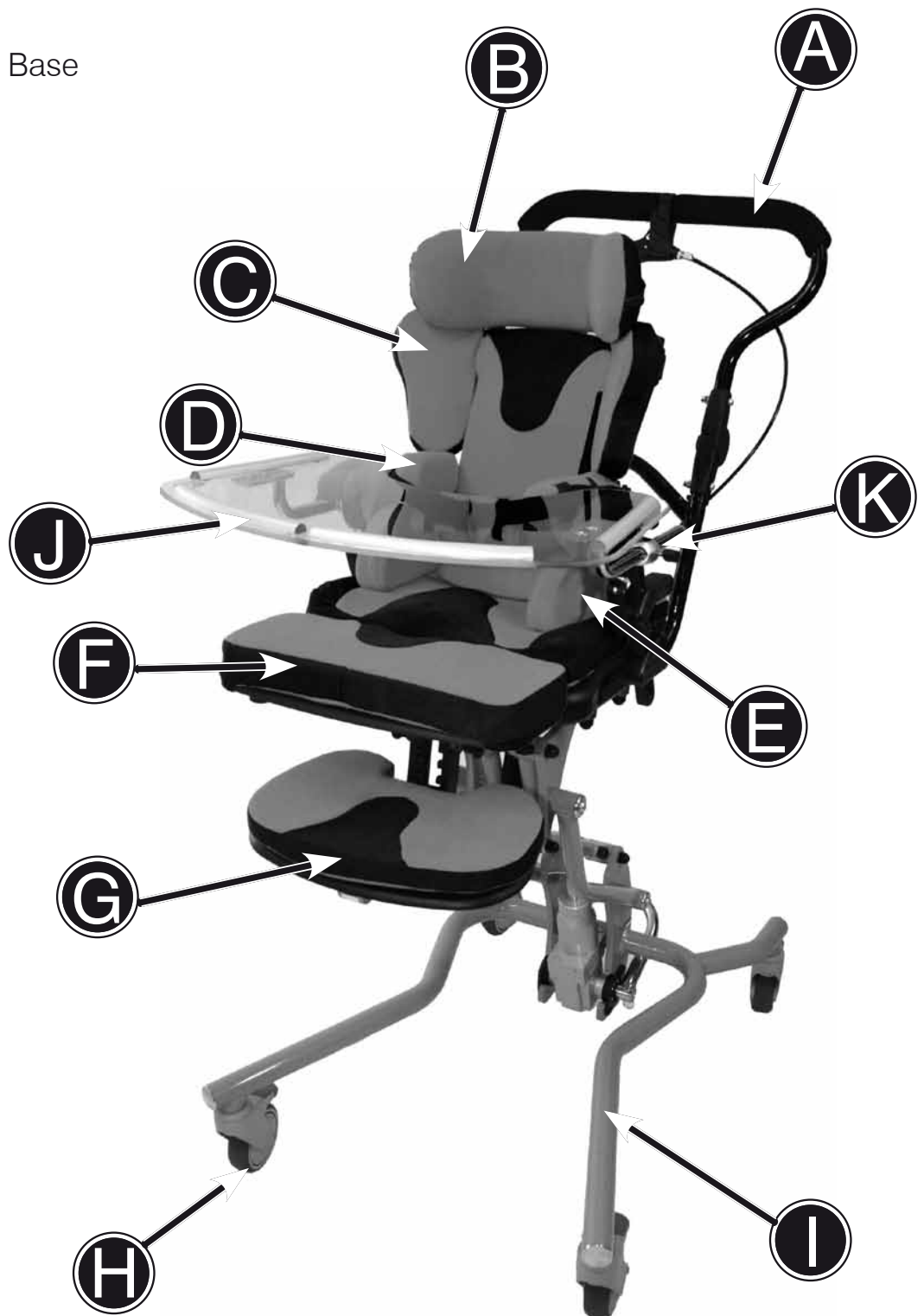

Important Safety Advice



We at JCM are committed to producing products of the highest standard. All of our products fulfil the essential safety and environmental requirements as defined in the European Directives. However, improper use of the products will potentially put the users at risk and therefore JCM strongly suggest that the following information is strictly adhered to at all times.

Throughout the manual there are important points to note identified by the symbol:



- Ensure all adjustment mechanisms are secure and in place before operation. If it is likely that the hand-wheels will be repeatedly loosened, JCM can supply allen key bolts as an alternative. We strongly recommend this if there is a danger from those in the vicinity of the user.
- After completing any alterations ENSURE all nuts, bolts, knobs, hand wheels and other fixings are securely tightened and in position, and that they are regularly checked as part of the maintenance of the chair. Never over adjust or over tighten moving parts.
- All postural support straps and harnesses should be in place and properly adjusted to the user, prior to usage of any kind (see pages 8 & 9).
- Whilst the seating system is stable on a 5-degree slope, it is not intended to be used in this manner, the Triton should always be positioned on a level, flat floor. The Triton chair can be moved between one working area and another. For safety ALWAYS return the product to a neutral position and lower before moving (lower in height, level the seat, ensure the back is upright etc). After the chair has been moved and during use the chair should be placed in a static position with the brakes applied. The multi height base is intended for indoor use only, though it is acceptable to take the base externally for a brief period if transferring the chair from one indoor area to another.
- Heavy items on the tray will affect stability. The fitting of anything other than the standard JCM tray may substantially affect the stability of the seating system and should therefore be checked before issue.
- If at any time it is noted that areas of the users skin remain reddened after being out of the seating system for around 10 minutes, urgently contact the qualified professional who performed the hand over of the equipment. This may be a sign of excessive pressure being exerted by the seating. This might occur in the initial use of a new seat where further adjustment may be required, where the user has been badly placed, grown or where an underlying medical problem exists. Review may be necessary in such cases
- Keep all products away from excessive sources of heat, cigarettes and naked flames.
- If you suspect that the system may be faulty, cease use of the equipment straight away and immediately contact the organization who supplied the system. (JCMs contact information can be found on the back cover).
- The equipment will be labelled with important information. NEVER REMOVE these information labels or allow them to be defaced, overlaid or altered.
- All modifications, adjustments, reconditioning, repairs, disposal, and servicing of the seating unit must ONLY be carried out by the agencies who supplied the equipment (see pages 24-25).

Important Safety Advice -(Accessories)

Multi Adjustable Head support

Wings on the head support are ideally set at 45 degrees. Do NOT bring the wings in tight to the head. Ensure that the head support is set in such a way that the child cannot loop their head around the wings and get stuck.

Flexi-Supports and Lateral Supports

Ensure the straps do not infringe on any feeding tubes the child may have.

Pommel

The pommel is designed to abduct the users knees to help keep the hips in a good position. Do NOT use the pommel as a way of holding the user in the seat. Remove the pommel when transferring the user in and out of the seat.

Foot Sandals and Straps

Should only be fixed when the user is wearing shoes or boots.

Tray

Do NOT use the tray as a way of securing children in a chair always ensure that the lap strap and any other straps supplied are used. Ensure that the tray clips are secure on both sides of the tray. If the tray is damaged, ensure that this will not be a hazard to the user. Never leave hot items on the tray while children are unattended.

Important - Chest Harness Adjustment



GREAT CARE should be taken when fitting a chest harness and the following points should always be followed:

- The straps on the harness should never be allowed to move close to or in any way cause an obstruction to the child's neck.
- The straps should never be fitted too tightly and should be clear from any obstruction.
- The sternum strap on the chest harness should always be adjusted prior to use to ensure that it is no higher than the middle of the user's chest.
- A lap strap should always be fitted if a harness is being used to ensure the child cannot slide down onto the sternum strap.
- Always ensure that the belts offer your child both comfort and support. If the child's clothing has been adjusted (i.e. a jumper removed) the straps should be re-adjusted accordingly.



Fixing Onto Chair

The straps at the top of the harness should be attached to the back frame of the chair. The Triton comes with a fixing point either side at the top back of the chair for attachment of straps and harnesses.



The straps at the bottom of the harness should be located to the back of the seat frame.

Fastening of Belts

- Feed the fabric belt through the buckle on the strap.
- The belts should be pulled through enough to suitably support your child whilst still being comfortable.
- When this has been achieved the buckle should be snapped closed to secure the strap in place.



The same precautions highlighted here should be adhered to when using any form of trunk supports or flexi supports with straps.



If there is any possible chance of the child getting the straps caught around their neck, **REMOVE THE HARNESS IMMEDIATELY.**

Important - Lap Strap Safety



Incorrect fitting of lap straps can put the user at serious risk. When using lap straps we recommend the following points should always be adhered to:

Lap Strap Fitting

The angle that the hip belt is attached to the seating system has a direct effect on the angle of pull on the pelvis.

Considerations:

- A 60° angle of attachment to the seat rail positions the hip belt anterior and inferior to the ASIS, which reduces the tendency of the client with a posterior pelvic tilt to slip underneath the belt.
- A higher angle of attachment of the primary straps encourages a posterior pelvic tilt, which assists in positioning clients with an anterior pelvic tilt.
- The secondary straps of a 4-point hip belt are attached to the seat post between 45° and 90° to hold the primary padded strap in place and to prevent the belt from riding into the abdomen or twisting.
- The angle of attachment may have to be compromised in order to accommodate such situations as wounds in the pelvic area, unstable hip joints or gastric tubes.

Tightening the belt

Keep belt tightened at adjustment straps during fitting and daily use to ensure correct pad placement. For padded hip belts the pads are to be touching when correctly tightened. For non-padded hip belts the

adjustment strap at the buckle should be approximately 3" (76mm) long. Education of the care giver is essential for correct hip belt positioning.

Sizing

Measure hip width to determine the belt size required. The suggested method for measuring hip width is from trochanter to trochanter. If this is not possible, measure from ASIS to ASIS and add a couple of inches. The correct belt size for the individual has padding that covers all of the bony prominences.

- Always check that the child's pelvis is symmetrical and positioned securely at the back of the seat.
- Always ensure that the lap straps and chest harness hold the child securely and are comfortable. Ensure they provide a snug fit, a simple rule of thumb is to allow two fingers to be inserted between the belt and the child's body.
- Never leave a child in a chair unattended without the lap strap being fastened.
- A lap strap should always be fitted if a harness is being used.
- When altering the angle between the seat and the back of the chair always re-adjust the chest harness and lap strap accordingly to ensure all safety recommendations are followed.

Harness and Lap Strap Positioning

This diagram shows the recommended positioning of the chest harness and lap straps:

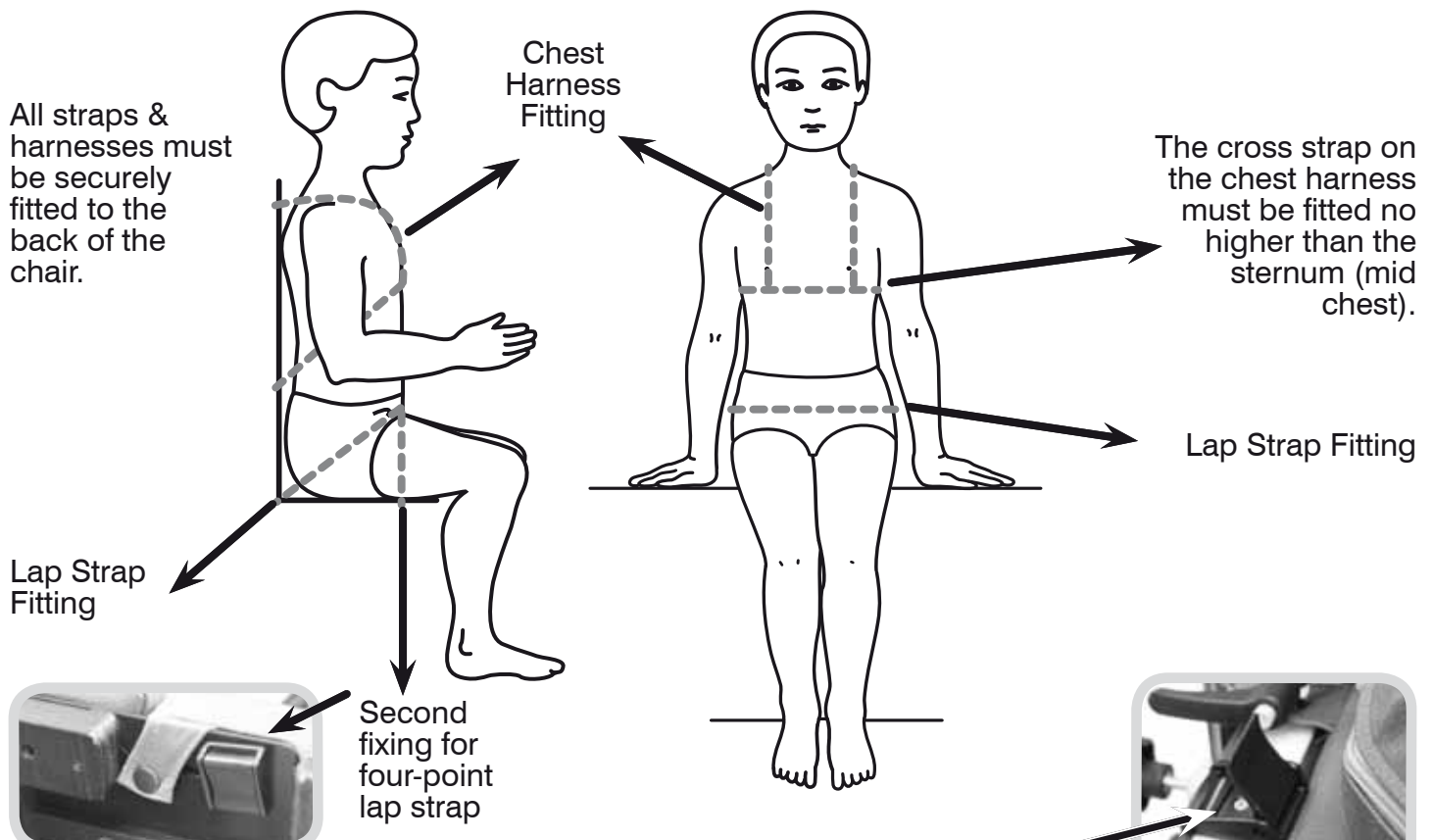

The chair comes with a fixing point either side at the top of the back for attachment of straps and harnesses.

Lever Use - Using Index Plungers

Using the Index Plungers (Locking Variety Only)

- To place the plungers in an open position - Pull out the plungers to maximum tension and turn them through a half turn anti-clockwise (B). This places them in an open position (C).

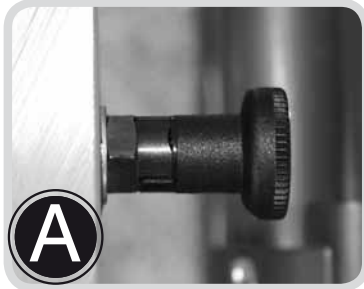

LOCKED

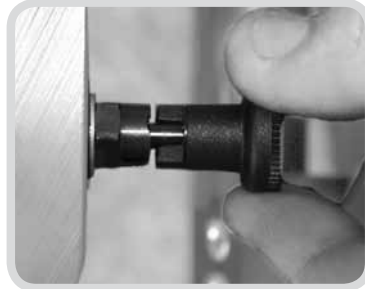

TURN

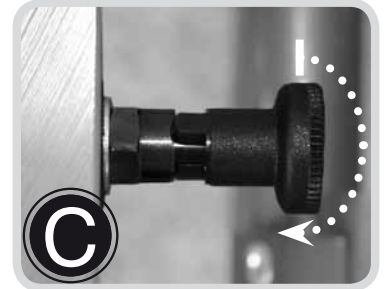

OPEN

- To close - Turn the plungers a half turn clockwise and they should snap back into a locked position (A).

Operation of Locking Levers

Effective Operation of Lock Levers (Where Fitted)

Never remove these levers entirely as this will prevent you from being able to perform adjustments in the future.

- To use:** Turn the lever handle clockwise to tighten or anti clockwise to loosen.
- To use the lever when an obstruction is met:** Pull the handle of the lever outwards, towards you (A). This disables the function of the lever.
- Continue to hold the lever out and reposition the lever handle in a suitable position past the obstruction.
- Release the handle to re-engage the lever function (B) and continue to tighten or loosen in the normal way.
- Repeat this procedure in areas where adjustment is restricted due to an obstruction.



Adjusting Seat Depth

A

view of underside of seat

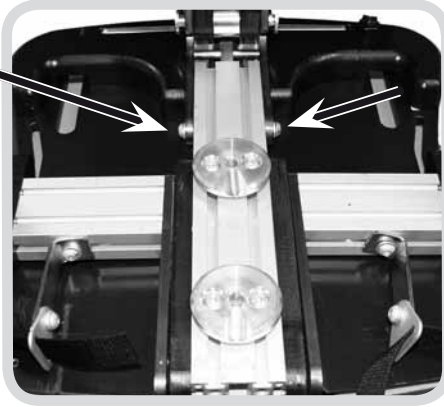

Step 1 - Seat Depth Increase (150-225mm of depth)

- Untighten screws (A) by a half turn, using the long allen key provided.
- Using one hand to steady the base, grasp the top of the leg rest firmly and

pull the seat forwards.

- Re-tighten the allen key bolts (A) to secure the seat in place.
- You can gain an additional 75mm seat depth forwards from 225-300mm by making another adjustment shown in step 2 below.

Step 2 - Seat Depth Increase (75mm extra depth 225-300mm)

- Push the seat back (reversing the process in step 1 leaving the allen key bolts (A) untightened).
- Pull out plunger (B) located at the back of the seat and turn 90 degrees anti-clockwise to set in an open position.
- Pull the metalwork (C) out at the back of the seat - (there are 2 protrusions which make up 1 unit and slide out together).
- Re-lock plunger (B) by turning 90 degrees clockwise, to secure the back frame in place.
- If required repeat Step 1 and use the optional cushion (D) to fill the space created at the back of the seat cushion.



B

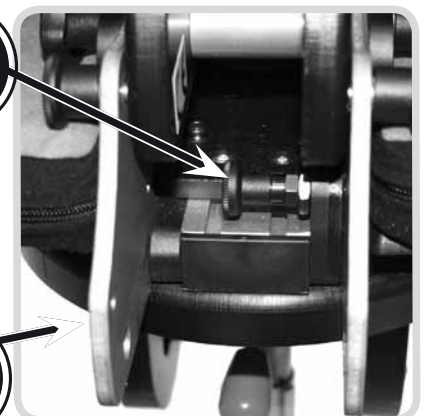

A

C

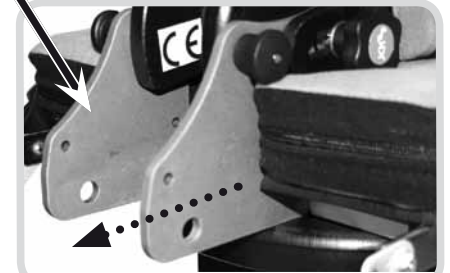

D

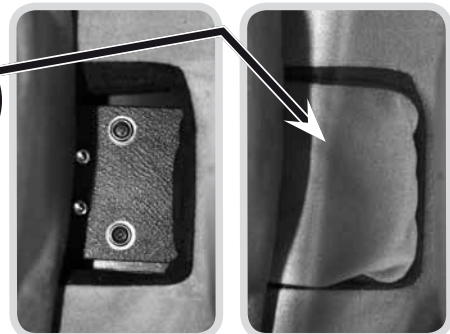

Once you have adjusted the seat length, always ensure these points are firmly fixed and are checked as part of maintenance of the chair.

Mounting of Seating Unit



Always ensure the base is stable and that the brakes are applied before mounting the seating unit.

- There are 2 cut outs on the top of the interface plate (A) which are for locating lugs (B) on the seating unit to fit into.

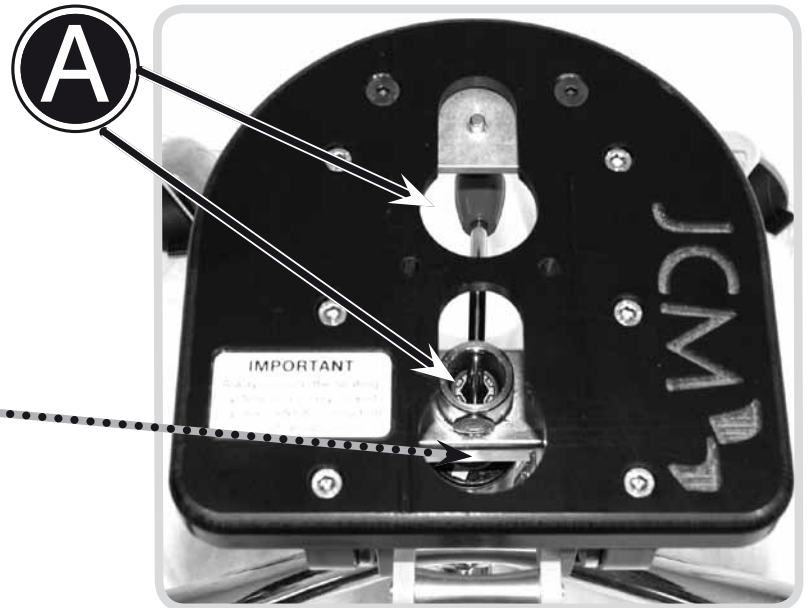
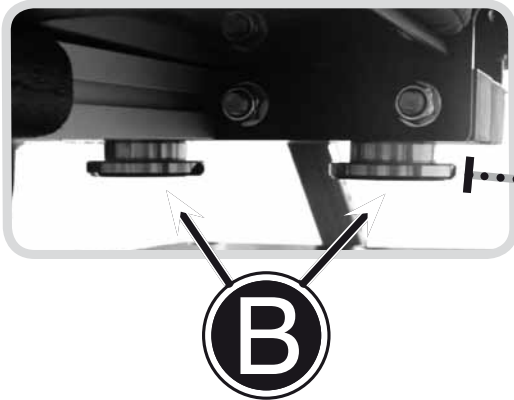

- Position the seating unit above the interface plate, lining up the locating lugs (B) with the cut outs (A) on the interface plate.
- Carefully lower the seat onto the interface plate ensuring the locating lugs (B) slide into the cut

outs on the interface plate (A).

- Push the seating unit inwards towards the back of the chair until the locating lugs 'click' into place.
- Ensure the seat is securely located on the base before using.



View from the side showing the seating unit lugs lowering into the interface plate cut outs.



View of seat engaged with the base.



Always ensure that the locating lugs are fully engaged and that seat is securely locked in place and secure on the base before using.

Removal of Seating Unit From Base

C

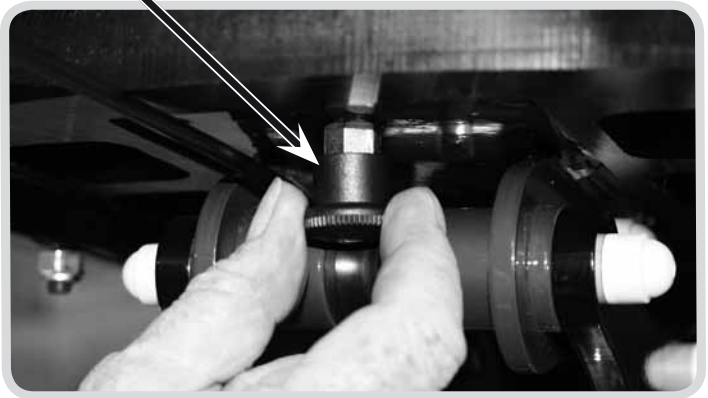
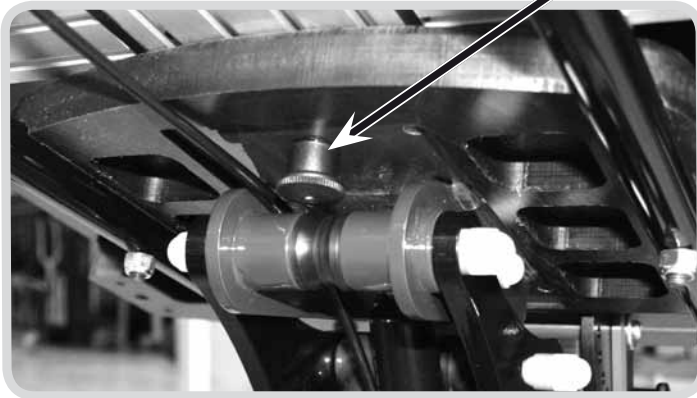

- Release index plunger (C) which is underneath the interface plate and slide seat forward to remove it from the base.

Operating Brakes

Applying Brakes

Depress lever (B) with your foot. To secure the chair in place you should suppress all the brakes fitted to the wheels on the base.



Releasing Brakes

To release the brakes you should flick the levers up using the top of your foot. When all brakes are released the chair will be free to travel in any direction.



Always apply the brakes while the chair is stationary.

Adjusting The 5 Star Base

To Raise The Chair

- Located at the back of the chair base push the red lever (A) downwards to raise the chair.

To Lower The Chair

- Whilst pushing the red lever (A) downwards, apply weight to the seat cushion and push down.

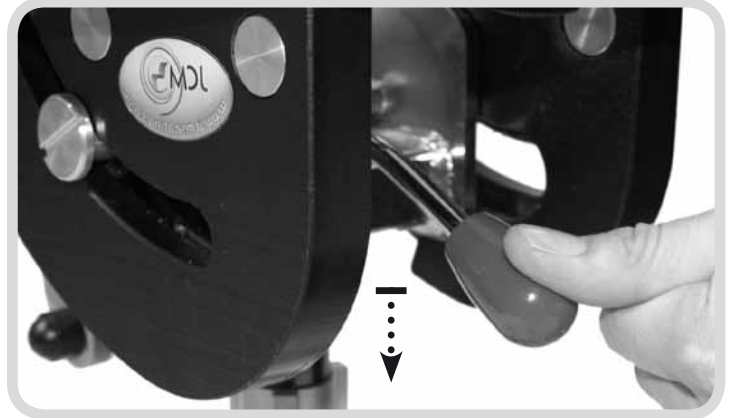

Adjusting The Tilt In Space on the 5 Star Base



- Lift up the safety latch (A) fully so that the grooves either side at the back of the latch clear the bar (C).
- Pull down the main latch (B) fully so that the grooves either side at the back of the latch clear the bar (C).
- Tilt the chair to the required position (supporting the chair as you adjust).

Shows the grooves on both of the latches.

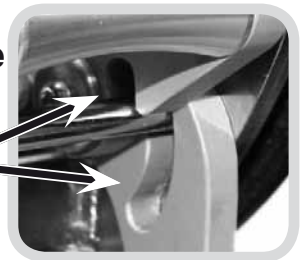

Groove on latch locked on to bar.

- When the desired angle of the chair is achieved, relocate the main latch (B) by pushing it up so that the bar (C) slots into the grooves either side at the back.
- Push the safety latch (A) down so that the bar (C) slots fully into the grooves either side at the back.
- Always ensure that both latches A and B are fully secured in place with grooves locked onto the bar (C) as show in fig (D).



Always ensure that both latches A and B are fully locked into place and that the groves at the back of each latch are fully engaged onto the bar (C) before allowing the chair to be used.

Adjusting The Multi Height & Tilt Base

Tilt In Space

- Squeeze the handle (A) on the chair push handle and push down on the handle to recline the chair or pull upwards to achieve a prone position.
- Once in position release handle (A) to lock the tilt mechanism.



Please note that the handle fitted is dependent on the size of the chair. You therefore need to ensure the size label on the handle matches the size of the chair being used.



The operator should control the motion of the chair while the squeeze handle is engaged. The amount of support required will vary with the size and weight of the user.

We recommend practicing this operation on first use before placing the client in the chair.

Seat Height Adjustment

The multi height and tilt base caters for all sizes of Triton. It is controlled by a hydraulic pump mechanism.

To Raise The Chair

- Pump the foot pedal several times until the desired height is reached. (The chair will raise with each pump.)

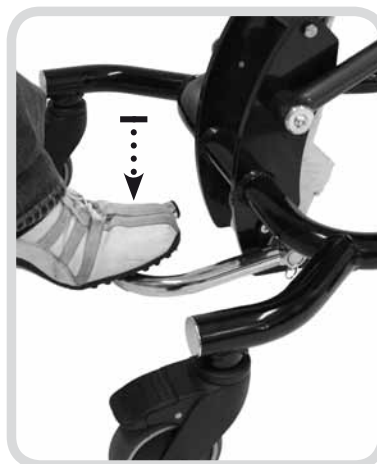

RAISE
Pump down on pedal

To Lower The Chair

- Place your foot under the pedal and gently lift the pedal up. (The chair will automatically lower.)



LOWER
Lift pedal up with foot

Folding The Push Handle

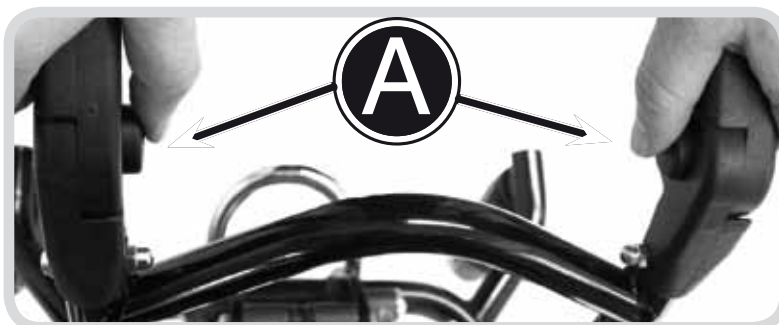

Only use the push handle to move the chair. The push handle should be folded down when not in use.

- Depress both buttons (A) on the inside of the handle.

- Manually alter the position of the handle by pushing the top section down.
- To unfold pull the handle up until you hear a click ensuring it is in place.

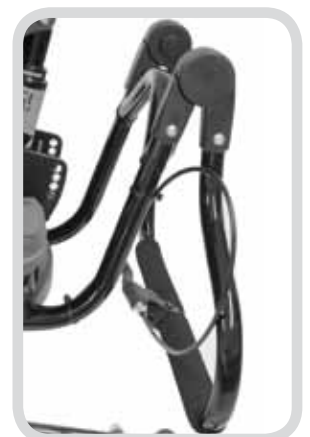

Back Angle Adjustment

- Pull out the left one of the plungers (A) and rotate to 90 degrees to place in an open position.
- Whilst holding out the right hand plunger (A), rotate the back of the chair into the desired position.
- Re-locate both plungers into another of the holes as shown at point (B). Lock the plungers into place by releasing the right hand plunger and twisting the left hand plunger in an anti-clockwise direction so that it slots closed. Fig (C) shows both plungers locked into place.

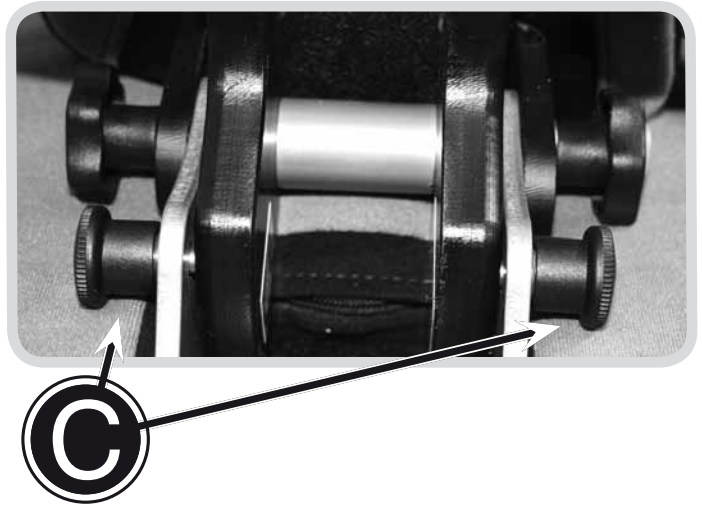
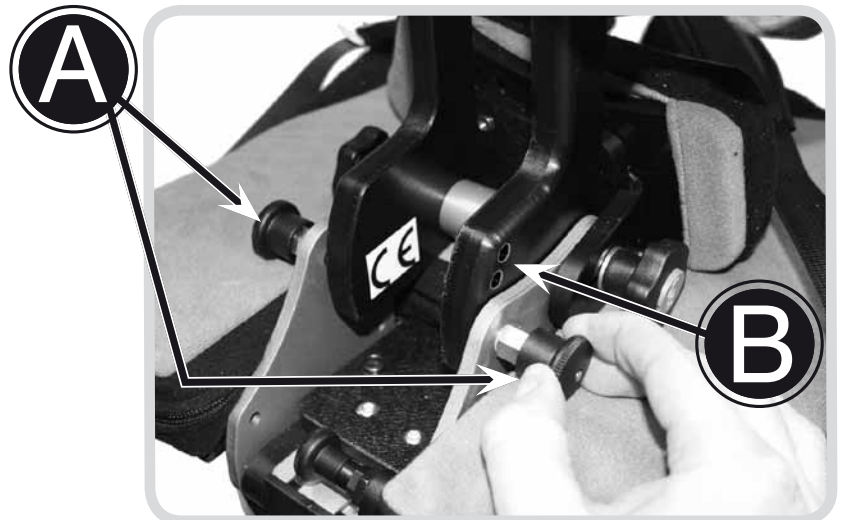

Always ensure that both plungers (A) are fully locked into place as in fig (C) and are fully engaged onto one of the holes (B) before allowing the chair to be used.

Back Height Adjustment

- Pull and hold out plunger (A) slide the bracket up or down along the casing, re-locating the plunger into one of the other holes along the back (B).

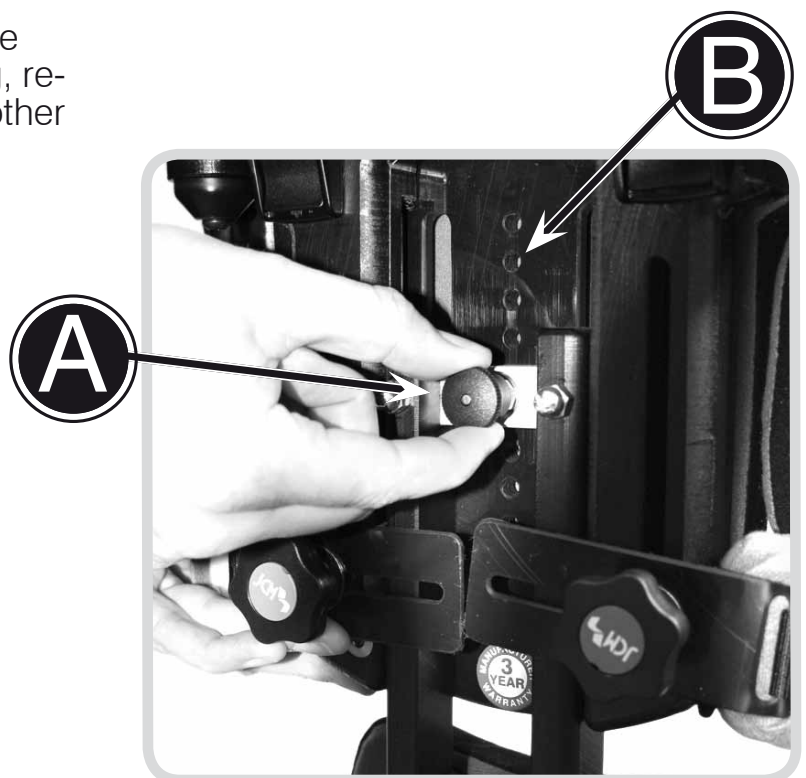

Adjusting Shoulder Protraction Pads

Pad Width

- The pad adjusts by friction alone. Pull or push the pad firmly in or out to adjust the pad width.

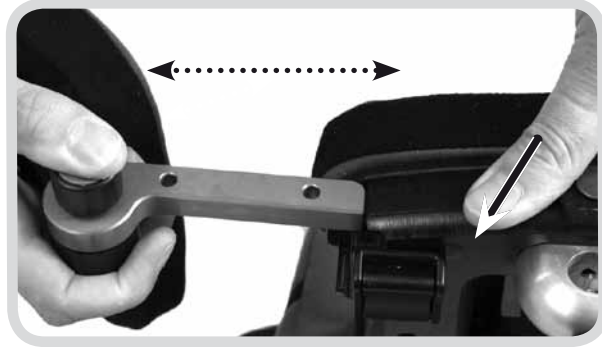

Pad Angle -Towards User

- Manually position the pad by pushing towards the front of the chair to give the correct amount of shoulder protraction - (the pad automatically locks itself into place).
- To increase the life of the ratchet mechanism, it is advisable to press the button to re-position the pad close to where it is required, using the ratchet lock to complete only fine adjustment.



To Flip Away From User

- Depress button (A) and hold down to flip the pad away from the user.
- Release button (A) to secure in place.

Fitting a Tray

- Line up the arms of the tray with the holes on the arms of the chair (A)

A



- Slide the arms of the tray through the holes until the desired position is reached.

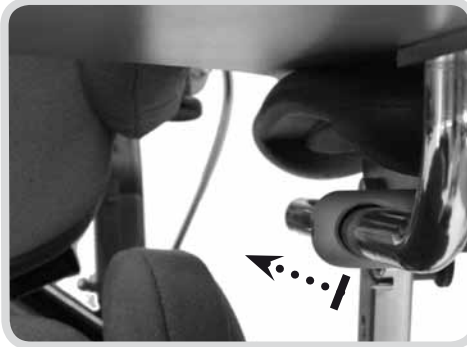

- Secure the tray in place with the hand wheel at the side of the chair arm.



Always ensure that the arms are fixed in position and the tray is secure before leaving the user unattended. Never leave anything hot on the tray while the client is unattended.

Arm Rest and Tray Angle Adjustment

- Pull out lever (A) and manually adjust the arm angle to the desired angle.
- Twist the lever (A) clockwise to tighten the lever and secure the arm in place.

A



- Lock the lever back into place to secure the arm by pushing it in towards the arm bracket as shown in Fig (B)



Always ensure that the arms of the chair are secure before using the chair.

Hip Pad Adjustment

Hip Pad Width

- Whilst holding plunger (A) up adjust the hip pad along the hip pad bar (B).
- Relocate the plunger into one of the relevant positioning holes on the hip pad bar (B).

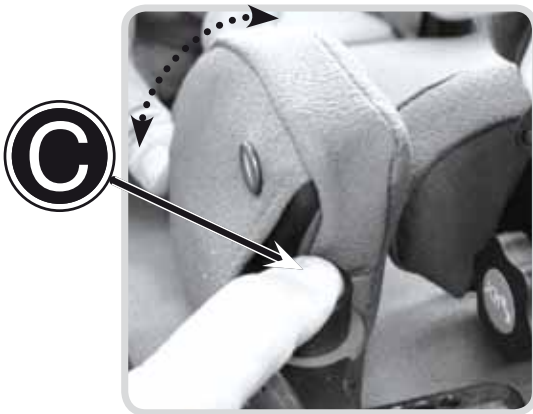
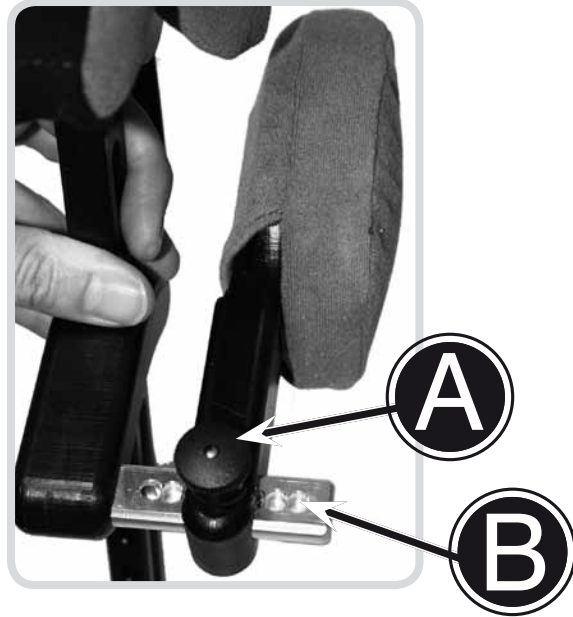

Hip Pad Angle

- Push down button (C).
- Manually adjust the pad to the desired angle.
- Release the button (C) to secure.

Lateral Support Adjustment

Height & Width of Supports

- Un-tighten allen key bolts (A) and manually move the lateral supports up and down or left and right within the slots to adjust.
- Re-tighten the allen key bolts securely to lock the supports in place.

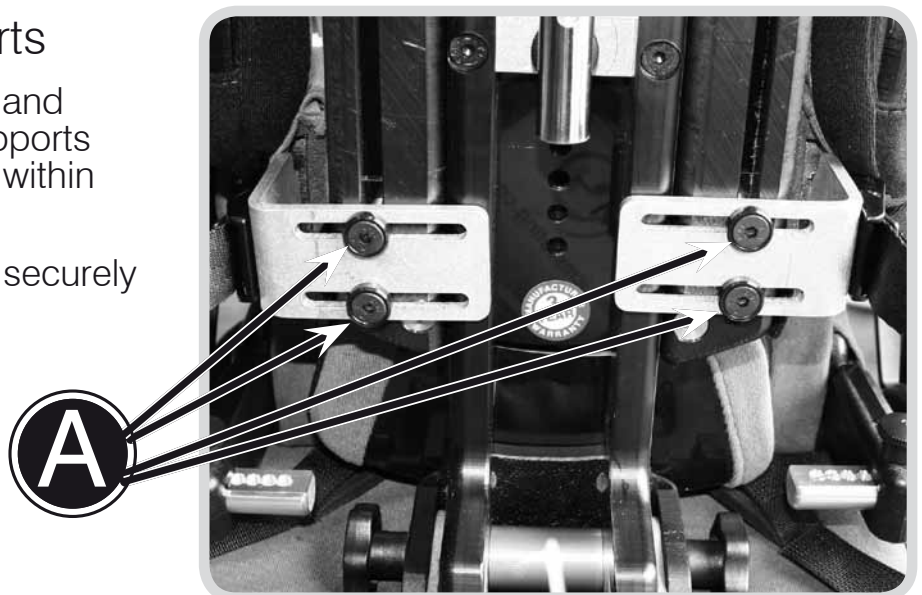

Check that the supports are not too high under the arms of the user or tight around chest area by running your fingers around the inside of the supports. Also check that the supports do not infringe on any feeding tubes.

Headrest Adjustment

Adjusting the Wing Angle

This adjustment point allows you to move the wing position to offer more side support to the head. This adjustment point allows you to alter the angle of the headrest to support the head and neck.

- Unzip the headrest cover at the back and loosen the allen key bolts (A).
- Adjust the sides of the headrest into the desired position.
- After desired position has been reached tighten the bolts to secure in place.

Perform this for either side wing of the headrest.

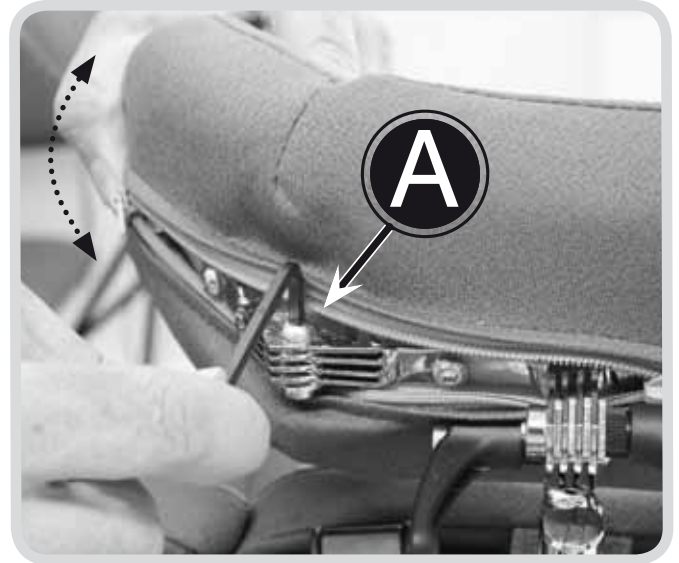

Adjusting the Headrest Angle

- Levers (B) should be operated together to achieve the desired head positioning of the user. Loosen the levers by turning anti-clockwise.
- Once loose, the head support angle can be manually adjusted to suit the user.
- Tighten the levers to secure in place.



Adjusting the Headrest Height

- Loosen the hand wheel (C)
- Slide the headrest up or down inside the bracket on the back of the chair.
- Re tighten the hand wheel to secure in place.



Always check that the headrest is secure and the wings are not tight around the head. The headrest wings are ideally set at 45 degrees to the back.

Sacral Pad Adjustment

Un-tighten both hand wheels (A) located either side of the sacral pad, this allows all of the adjustments below to be made.

Lateral Rotation

- Twist the pad left and right as desired.

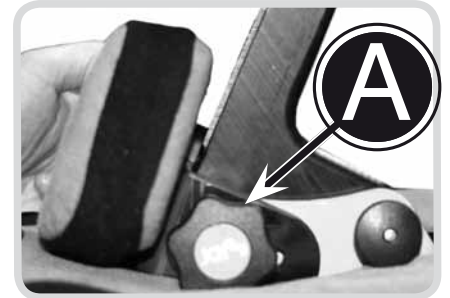

Fore and Aft

- Slide the pad forwards and backwards within the slot (B).

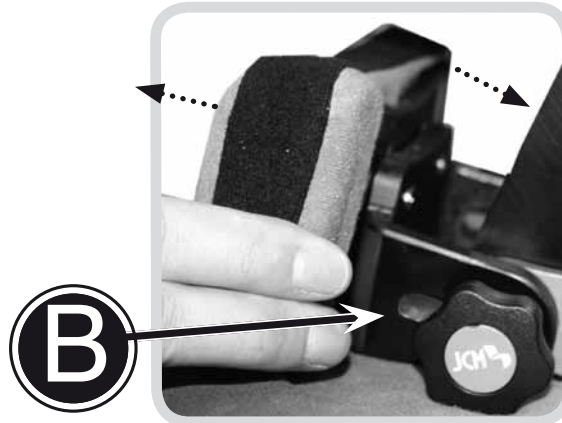

Posterior and Anterior Rotation

- Rotate the pad about its axis.

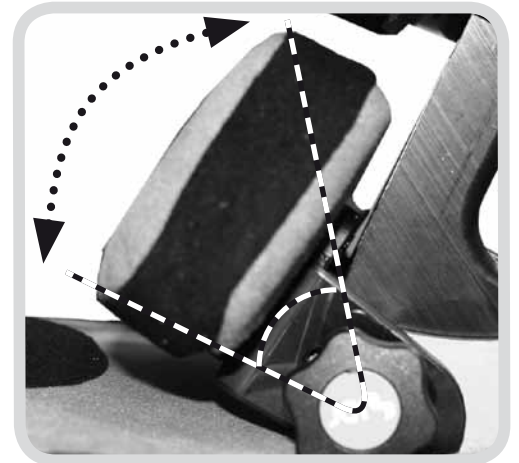

Pad Height

- Un-tighten both allen key bots (C) and adjust up and down along the slots.

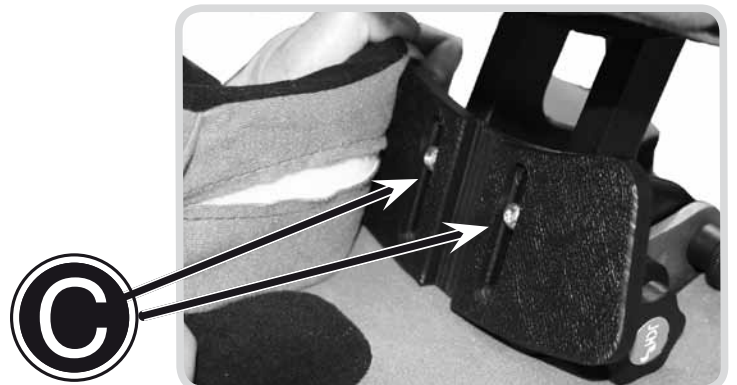

Always ensure that both hand wheels (A) either side are tightened to secure the pad in place.

Footplate & Leg Rest Adjustment

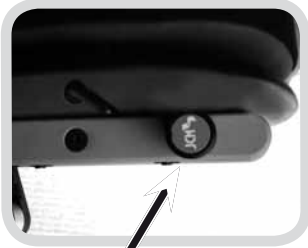

A

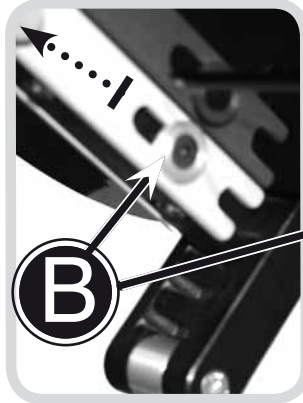

B

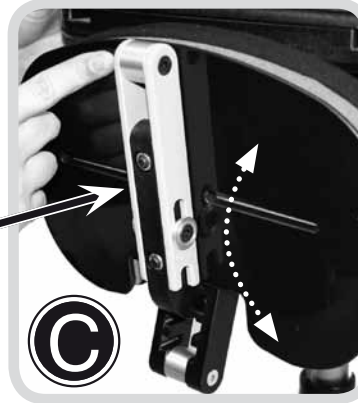

C



D

Footplate and Leg Rest Height

- Push button (A) located on the underside of the footplate in.
- Pull bar (B) located on the underside of the footplate out away from the chair.
- The footplate can now either be flipped and held up as in fig (C) or it can be adjusted in height.
- Slide the footplate up or down the bracket (D) as required and re-locate bar (B) by pushing the groove on the end onto one of the teeth on bracket (D). Ensure that bar (B) is securely located onto one of the teeth and pushed on as far as it will go before resuming use of the chair.

Removal of Leg Rest and Footplate for Standing Transfer

- Pull out the plunger on the left and rotate by 90 degrees to put into an open position (E).

E

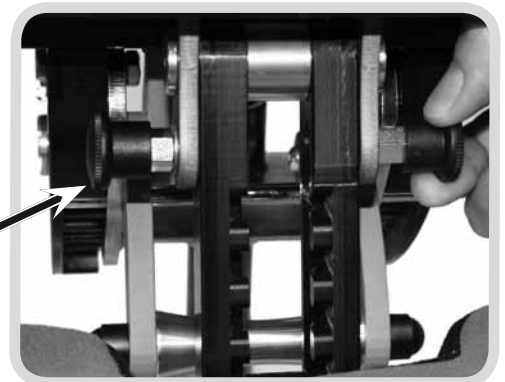

- Hold out the plunger on the other side whilst you push the bracket (F) upwards and towards the chair. Unhinge off the hooks at the top.
- Reverse the whole process above to put the leg rest back on, ensuring the plungers are secured into place.



F



Always ensure that the plungers are fully located and locked into place before using the chair.

Footrest, Footplate & Sandal Adjustment

Removal of the Foot Pad Cushion for Sandal Use

- For sandal use the foot pad cushion can be easily removed simply by un-clipping the 4 press studs which attach the pad to the plastic base as shown in fig (D).

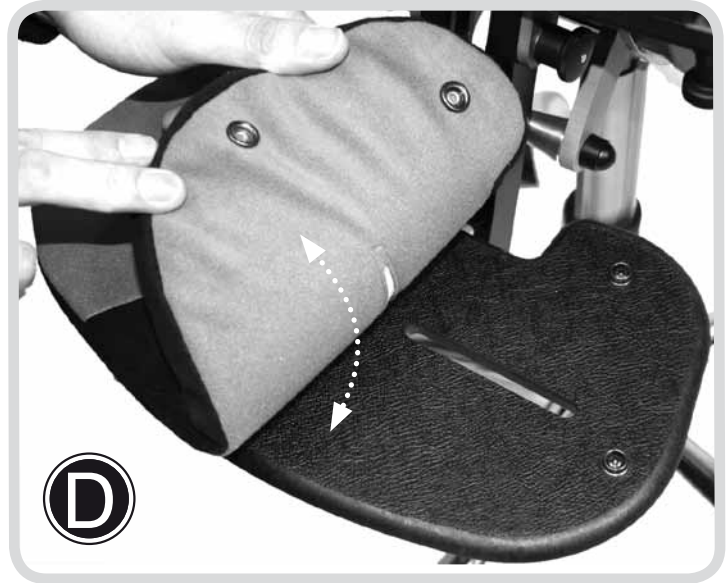

Sandal Rotation

- Underneath the footplate loosen the central allen key bolts by turning anti-clockwise.
- Rotate the sandal to the desired position along slot (G).
- Fix in place by tightening the allen key bolts beneath the footplate.

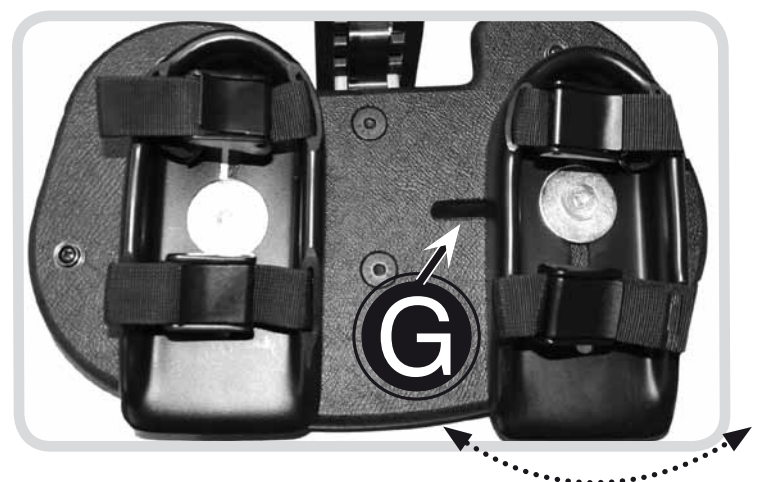
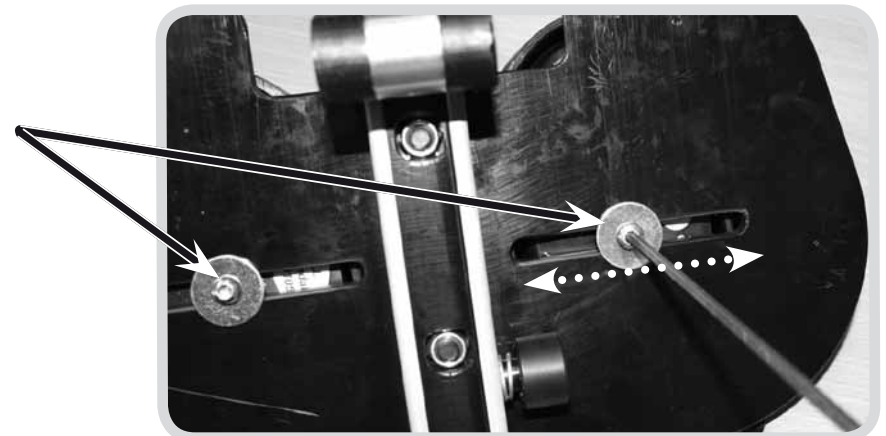

Foot Straps

Foot straps or ankle huggers can be attached through the slots in the footplate to secure feet. Feed the strap through the buckle and close the buckle shut to secure.



Do not use foot straps unless the client is wearing shoes.

Cleaning & Care

We recommend the following points for successful cleaning of your equipment. (It is possible that some surface wrinkling may occur following these processes)

Fabric Upholstery Care

Refer to JCMs fabric cleaning guide which can be found on their website www.jcmseating.co.uk
Do not use bleach, acidic, solvent, abrasive, biological or phenolic based cleaners.

Metal Framework

- If all upholstery is removed the metal framework can be cleaned with hot soapy water and detergent or it can be steam cleaned. (Labelling may need to be replaced following steam cleaning).
- Ensure that the framework is thoroughly dried after cleaning.
- Always ensure that any moving or adjustable parts are re-lubricated.

General Maintenance



General maintenance should be carried out by a competent, professional person who is well informed on how to use the equipment (see warranty - page 29) if there is no such person available or a more thorough check is needed, a service via an approved repairer (see opposite) should be booked. The person who carries out the maintenance check or service should always fill out the service history log record (page 28) in order to ensure the warranty remains valid.

As documented opposite, the degree of maintenance required is dependant on various factors relating to the use of the product. In addition to the specific functional adjustment warnings specified in this manual, it should be ensured that a thorough inspection of the following should be completed at no greater than 6 month intervals: (Points listed here are generic across the JCM range and do not apply to all products).

Castors	<ul style="list-style-type: none"> • Lift base and check each wheel to ensure it is not damaged, loose or worn.
Brakes	<ul style="list-style-type: none"> • Removing any grease or dirt that has built up on the wheels, check that the brakes stop the wheels rotating. • Check they are securely fixed in place & that there are no signs of damage or wear & tear.
Pushing Handles	<ul style="list-style-type: none"> • Ensure handles are functioning correctly. • Check there are no signs of damage or wear and tear. • Ensure push handle grips are secure.
Seat Tilt In Space Mechanism	<ul style="list-style-type: none"> • With the tilt lock released check for free movement with no signs of damage or wear to the mechanism, lever or cables. • Tighten the lock and ensure it holds the seat angle.
Base Height Adjustment	<ul style="list-style-type: none"> • With the seat unloaded, press the lever & ensure it moves freely to the maximum height. • Place the appropriate maximum load (40, 60, 80 or 100kgs) and, over a period of time (approx 10 - 15 minutes), check that there is no creep (lowering) of the seat. If it is not practical to perform this test, as a minimum requirement, immediately following the maintenance check, the static position of the seat should be monitored whilst a user is positioned in the system. • With the load on, press the lever & ensure the seat travels freely to the lowest position.
Seat / Backrest Upholstery	<ul style="list-style-type: none"> • Check the attachment points of the seat and backrest upholstery are tight. • Check for worn covering. Rough worn upholstery can cause discomfort, would be difficult to keep hygienically clean, and may cause skin irritation.
Interface	<ul style="list-style-type: none"> • Check there are no signs of damage or wear and tear. • Ensure the function secures the seating unit properly.
Frame With correct maintenance the frame should provide at least 5 years trouble free use but, depending on conditions of use, wear will occur and a thorough inspection is recommended.	<ul style="list-style-type: none"> • Check all metal parts to ensure there are no signs of damage or wear and tear, paying particular attention to adjustable or moving parts. • Check there are no signs of failure in joints and welds. • Check tightness & security of all fixings, bolts, nuts, spring loaded pegs, & other fitments. • Check for signs of fatigue wears, replace parts that show signs of wear or repeatedly becoming loose. • ANCHOR POINTS (where applicable) for transportation must be checked to ensure security, check there are no signs of damage, wear and tear or failure.
Fixtures	<ul style="list-style-type: none"> • Check arm pads and headrest and replace if worn.

Servicing via Approved Repairer

What should be completed during a service?

A service is a comprehensive combination of inspection, maintenance and repair or replacement of worn, faulty or missing components. The growth and any changes of the occupants needs since the original assessment is taken into account when performing the service. This is in contrast to general maintenance (opposite), where only straightforward checks, inspections and adjustments take place and primary services are planned.

What happens if a fault is found?

If any faults are found that could prove to be a risk to either the user or the operator then all use of the equipment should be ceased immediately until the product has been repaired.

Who should carry out the service?

It is stressed that only a JCM approved repairer or a person with competent training of a Class 1 medical device should carry out this work.

Any modifications must not be carried out without prior agreement of JCM Seating Solutions Ltd. It must be understood that unauthorised modifications may pose a risk to users and attendants. Unauthorised modifications will also invalidate the warranty.

Any new parts required should be genuine JCM Seating Solutions Ltd. approved parts, fitted to JCM specifications.

Frequency of Service

JCM recommend that a service of this product is completed once every 6 months as a minimum. However, the frequency of inspection and service must be altered depending upon the severity of use. If the system is used in any of the following ways then the use could be said to be fairly heavy and constant. Therefore we would recommend the service interval be reduced to once every three months;

- Daily for around 8 to 10 hours.
- Weekly for at least 6 days out of 7.
- Monthly for at least 11 months a year.
- By an active user or somebody who is very active voluntarily or involuntarily.
- By a user who is above 80% of the maximum user weight recommended.
- Transported in a moving vehicle twice or more in a day.

If the usage exceeds the amount highlighted above it is possible that services every six weeks or less might be needed.

How To Book A Service

JCM have specified technicians trained to service our products. If you would like JCM to service your chair or for further information please contact us on 01733 405830.

Alternatively, contact the person who issued you with the product.

Warranty

3 YEAR WARRANTY

Products manufactured by JCM are covered with a manufacturers 3 year warranty.

What it Covers

The warranty covers all aspects of product failure due to faulty workmanship or manufacturing.

Period of Cover

The period of the warranty runs for 3 years from the date that the product is dispatched.

The Work JCM is Obligated to Complete

JCM's obligation under this warranty is to replace or repair any defective goods within the period of the warranty free of charge.

What the Warranty Does Not Cover

- Items that are damaged or fail due to natural wear and tear, extreme usage, neglect or misuse.
- Accidental damage, modifications or repairs carried out by a third party unauthorized by JCM or non professional healthcare representative.

Customer Responsibility

To ensure the warranty remains valid, customers are advised that servicing, maintenance and re-issuing guidelines must be followed and documented as stated in the manual.

JCM will require proof of service (see opposite) for any warranty claims or orders.

When making a claim JCM reserve the right to inspect the product and all necessary documentation.

Only valid for products purchased after 1st April 2006. Applies only to products exclusively manufactured by JCM.



3 YEAR WARRANTY

IMPORTANT

JCM Seating Solutions Ltd. will not be held responsible for any damage or injury caused by incorrect use of this product. For any information or guidance on the use of this product please call our office who will put you through to your local representative or send you any additional information you may require.

Tel: 01733 405830

Inspecting & Reissuing of Equipment

Most JCM Seating Solutions Ltd. products are individually assessed for a client prior to issue. They are handed over in a controlled way to ensure optimum fit and specification, checks are completed and any additional individual verbal instructions given. We therefore recommend the following points are adhered to prior to any re-issue of equipment:

- **Cleaning**

Follow a rigorous process of cleaning in order to decontaminate the product and eliminate the chance of cross infection.

- **Assessment of Fabrics / Foams**

Carefully assess the condition of fabrics and foams in the seating product, and have these replaced partially or even completely if need be. In severe cases if the chassis is worn and the seating in poor condition it may be necessary to have the product re-furnished by the manufacturer. In very severe cases if the chassis is badly worn and the seating in very poor condition then the product should be decommissioned and disposed of.

- **Electrical and Electronic Equipment Decommissioning**

If your product is set up with an electrical function you should always contact JCM or your authorised representative for de-commissioning information.

- **Appropriateness of Equipment**

Check that the equipment supplied is appropriate for the needs of the user taking age, weight, ability, diagnosis, and any other important factors into account. For instance, JCM Seating Solutions Ltd. products may not be suitable for persons with severe challenging patterns of behaviour. Also ensure safe specified limits for use are not exceeded by the new user. Your sales representative can advise on the suitability of the equipment.

- **Manuals and Records**

Ensure this instruction manual and any additional manuals for the seating unit are handed over to the new user with the equipment and ensure the servicing log history is up to date. Records on the new user must be updated to maintain traceability.

- **Inspection**

The equipment should have a rigorous inspection prior to the reissue, to include the points covered in the six monthly routine check, regardless of if the checks were recently completed. The equipment should be free of excessive wear or distortion in any aspect of its main construction or accessories.

- **Condition**

Wheels, tyres and brakes must be in good working condition, properly adjusted and

inflated as appropriate.

- **Accessories**

Check all accessories carefully for damage and potential shortcomings which may pose a risk to the user.

- **Function**

Ensure that all the functions of the chair are working correctly e.g. tilt in space, height adjustment, back recline, folding etc.

- **Fixings**

Check that any knobs, hand wheels, nuts, bolts, levers and fixings are in good condition and fitted in place securely.

- **Modifications**

Any special modifications, adaptations, alterations or other such procedures including added accessories may require review. If they are found inappropriate, remedial action (if considered safe and practical) should be taken to reverse them if possible.

- **Labelling**

Any labelling specific to the previous user should be removed and replaced with labelling specific to the new user.

- **Adjustment**

Adjustment of the equipment to the new user must be carried out by suitably qualified and experienced professionals. These adjustments along with the other appropriate checks and tests should be completed with the owners knowledge and agreement.

- **Hand Over**

Competent handing over of the equipment to the new user or attendant must include proper training and advice in safe use, particularly regarding transportation issues.

- **Packaging**

Always ensure that the chair is packaged correctly before delivery.

- **Handle Fitting**

Please note that the handle fitted is dependent on the size of the chair. You therefore need to ensure the size label on the handle matches the size of the chair being used.



design for living

.....

15 -18 Maxwell Road,
Woodston Industrial Estate,
Peterborough,
Cambridgeshire
PE2 7HU

Tel: 01733 405830
Fax: 01733 405838
Email: enquiries@jcmseating.co.uk



INVESTOR IN PEOPLE

